



TRB246

v1.1



HARDWARE

FRONT VIEW

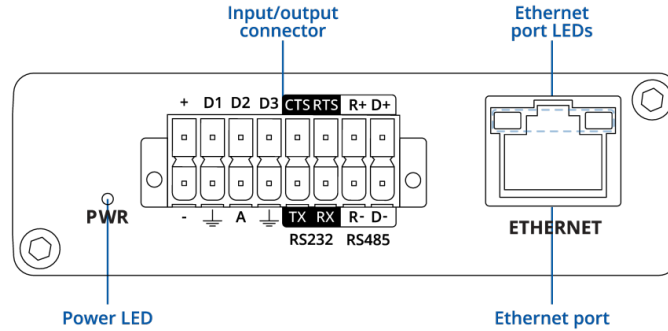

BACK VIEW

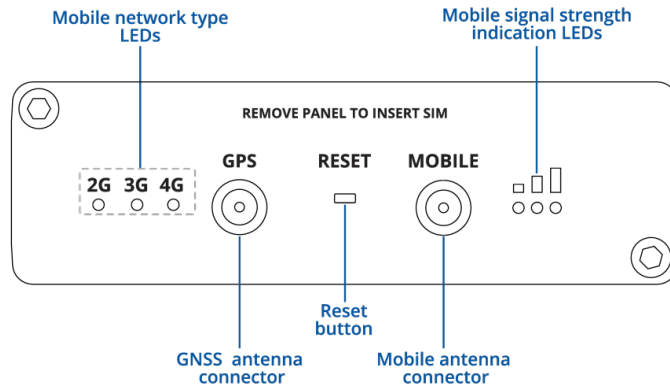

INPUT/OUTPUT 16-PIN CONNECTOR PINOUT

D1, D2, D3 - Configurable digital Input/Output pins. Open collector output, max output 30 V, 300 mA or Digital input where 0-6 V detected as logic low and 8-30 V – logic high.

+ - 9-30 VDC positive power pin

CTS - RS232 clear data to send pin (output).

RTS - RS232 request data to send pin (input).

R+ - RS485 receiver positive signal pin.

D+ - RS485 driver positive signal pin.

-- - Negative/ground power pin.

⊥ - Ground pins for D1, D2, D3, A, RS232 and RS485.

A - Analog input pin. Analog voltage range 0-30 V.

TX - RS232 transmitted data (input).

RX - RS232 received data (output).

R- - RS485 receiver negative signal.

D- - RS485 driver negative signal.

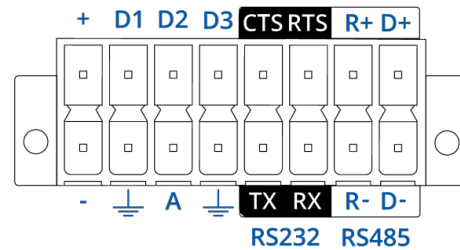

FEATURES

Mobile

Mobile module	4G LTE up to 150 DL/50 UL Mbps; 3G up to 42 DL/5.76 UL Mbps; 2G up to 296 DL/236.8 UL Kbps
3GPP Release	Release 11
SIM switch	2 SIM cards, auto-switch cases: weak signal, data limit, SMS limit, on roaming, no network, network denied, data connection fail
Status	IMSI, ICCID, operator, operator state, data connection state, network type, bandwidth, connected band, signal strength (RSSI), SINR, RSRP, RSRQ, EC/IO, RSCP, data sent/received, LAC, TAC, cell ID, ARFCN, UARFCN, EARFCN, MCC, and MNC
SMS	SMS status, SMS configuration, send/read SMS via HTTP POST/GET, EMAIL to SMS, SMS to EMAIL, SMS to HTTP, SMS to SMS, scheduled SMS, SMS autoreply, SMPP
USSD	Supports sending and reading Unstructured Supplementary Service Data messages
Black/White list	Operator black/white list (by country or separate operators)
Multiple PDN	Possibility to use different PDNs for multiple network access and services
Band management	Band lock, Used band status display
SIM idle protection service	When working with devices with two SIM slots, the one not currently in use will remain idle until the device switches to it, meaning that no data is used on the card until then
SIM PIN code management	SIM PIN code management enables setting, changing, or disabling the SIM card's PIN
APN	Auto APN
Bridge	Direct connection (bridge) between mobile ISP and device on LAN
Passthrough	Gateway assigns its mobile WAN IP address to another device on LAN

Ethernet

Ethernet	1 x ETH port, 10/100 Mbps, compliance with IEEE 802.3, IEEE 802.3u, 802.3az standards, supports auto MDI/MDIX crossover
-----------------	---

Network	
Routing	Static routing, Dynamic routing (BGP, OSPF v2, RIP v1/v2, EIGRP, NHRP), Policy based routing
Network protocols	TCP, UDP, IPv4, IPv6, ICMP, NTP, DNS, HTTP, HTTPS, FTP, SMTP, SSL v3, TLS, ARP, VRRP, PPP, PPPoE, UPNP, SSH, DHCP, Telnet, SMPP, SNMP, MQTT, Wake On Lan (WOL), VXLAN
VoIP passthrough support	H.323 and SIP-alg protocol NAT helpers, allowing proper routing of VoIP packets
Connection monitoring	Ping Reboot, Wget Reboot, Periodic Reboot, LCP and ICMP for link inspection
Firewall	Port forward, traffic rules, custom rules, TTL target customisation
Firewall status page	View all your Firewall statistics, rules, and rule counters
Ports management	View device ports, enable and disable each of them, turn auto-configuration on or off, change their transmission speed, and so on
Network topology	Visual representation of your network, showing which devices are connected to which other devices
Hotspot	Captive portal (hotspot), internal/external Radius server, Radius MAC authentication, SMS authorisation, SSO authentication, internal/external landing page, walled garden, user scripts, URL parameters, user groups, individual user or group limitations, user management, 9 default customisable themes and optionality to upload and download customised hotspot themes
DHCP	Static and dynamic IP allocation, DHCP relay, DHCP server configuration, status, static leases: MAC with wildcards
QoS / Smart Queue Management (SQM)	Traffic priority queuing by source/destination, service, protocol or port, WMM, 802.11e
DDNS	Supported >25 service providers, others can be configured manually
DNS over HTTPS	DNS over HTTPS proxy enables secure DNS resolution by routing DNS queries over HTTPS
Network backup	Mobile, VRRP, Wired options, each of which can be used as an automatic Failover
SSHFS	Possibility to mount remote file system via SSH protocol
Traffic Management	Real-time monitoring, wireless signal charts, traffic usage history

Security

Authentication	Pre-shared key, digital certificates, X.509 certificates, TACACS+, Internal & External RADIUS users authentication, IP & login attempts block, time-based login blocking, built-in random password generator
Firewall	Preconfigured firewall rules can be enabled via WebUI, unlimited firewall configuration via CLI, DMZ, NAT, NAT-T, NAT64
Attack prevention	DDOS prevention (SYN flood protection, SSH attack prevention, HTTP/HTTPS attack prevention), port scan prevention (SYN-FIN, SYN-RST, X-mas, NULL flags, FIN scan attacks)
VLAN	Tag-based VLAN separation
Mobile quota control	Mobile data limit, customizable period, start time, warning limit, phone number
WEB filter	Blacklist for blocking out unwanted websites, Whitelist for specifying allowed sites only
Access control	Flexible access control of SSH, Web interface, CLI and Telnet
SSL certificate generation	Let's Encrypt and SCEP certificate generation methods

VPN

OpenVPN	Multiple clients and a server can run simultaneously, 27 encryption methods
OpenVPN Encryption	DES-CBC 64, RC2-CBC 128, DES-EDE-CBC 128, DES-EDE3-CBC 192, DESX-CBC 192, BF-CBC 128, RC2-40-CBC 40, CAST5-CBC 128, RC2-64-CBC 64, AES-128-CBC 128, AES-128-CFB 128, AES-128-CFB1 128, AES-128-CFB8 128, AES-128-OFB 128, AES-128-GCM 128, AES-192-CFB 192, AES-192-CFB1 192, AES-192-CFB8 192, AES-192-OFB 192, AES-192-CBC 192, AES-192-GCM 192, AES-256-GCM 256, AES-256-CFB 256, AES-256-CFB1 256, AES-256-CFB8 256, AES-256-OFB 256, AES-256-CBC 256
IPsec	XFRM, IKEv1, IKEv2, with 14 encryption methods for IPsec (3DES, DES, AES128, AES192, AES256, AES128GCM8, AES192GCM8, AES256GCM8, AES128GCM12, AES192GCM12, AES256GCM12, AES128GCM16, AES192GCM16, AES256GCM16)
GRE	GRE tunnel, GRE tunnel over IPsec support
PPTP, L2TP	Client/Server instances can run simultaneously, L2TPv3, L2TP over IPsec support
Stunnel	Proxy designed to add TLS encryption functionality to existing clients and servers without any changes in the program's code
DMVPN	Method of building scalable IPsec VPNs, Phase 2 and Phase 3 and Dual Hub support
SSTP	SSTP client instance support
ZeroTier	ZeroTier VPN client support
WireGuard	WireGuard VPN client and server support
Tinc	Tinc offers encryption, authentication and compression in it's tunnels. Client and server support.

BACNET

Supported modes	Router
Supported connection types	RS485, TCP
Configuration options	Support for multiple BACnet/IP interfaces, Network number assignment, Preconfigured BDT entries for BBMD (BACnet Broadcast Management Device)

OPC UA

Supported modes	Client, Server
Supported connection types	TCP

MODBUS

Supported modes	Server, Client
Supported connection types	RTU (RS232, RS485), TCP
Custom registers	MODBUS TCP custom register block requests, which read/write to a file inside the router, and can be used to extend MODBUS TCP Client functionality
Supported data formats	8-bit: INT, UINT; 16-bit: INT, UINT (MSB or LSB first); 32-bit: float, INT, UINT (ABCD (big-endian), DCBA (little-endian), CDAB, BADC), HEX, ASCII

DATA TO SERVER

Protocol	HTTP(S), MQTT, Azure MQTT, Kinesis
Data to server	Extract parameters from multiple sources and different protocols, and send them all to a single server; Custom LUA scripting, allowing scripts to utilize the router's Data to server feature

MQTT Gateway

Modbus MQTT Gateway	Allows sending commands and receiving data from MODBUS Server through MQTT broker
----------------------------	---

DNP3

Supported modes	Station, Outstation
Supported connection types	RS232, RS485, TCP

DLMS

DLMS Support	DLMS - standard protocol for utility meter data exchange. Support trough serial and TCP
Supported modes	Client
Supported connection types	RS232, RS485, TCP

API

Teltonika Networks Web API (beta) support	Expand your device's possibilities by using a set of configurable API endpoints to retrieve or change data. For more information, please refer to this documentation: https://developers.teltonika-networks.com
--	---

Monitoring & Management

WEB UI	HTTP/HTTPS, status, configuration, FW update, CLI, troubleshoot, multiple event log servers, firmware update availability notifications, event log, system log, kernel log, Internet status
FOTA	Firmware update from server, automatic notification
SSH	SSH (v1, v2)
SMS	SMS status, SMS configuration, send/read SMS via HTTP POST/GET
Call	Reboot, Status, Mobile data on/off, Output on/off, answer/hang-up with a timer
TR-069	OpenACS, EasyCwmp, ACSLite, tGem, LibreACS, GenieACS, FreeACS, LibCWMP, Friendly tech, AVSystem
MQTT	MQTT Broker, MQTT publisher
SNMP	SNMP (v1, v2, v3), SNMP Trap, Brute force protection
JSON-RPC	Management API over HTTP/HTTPS
RMS	Teltonika Remote Management System (RMS)

IoT Platforms

ThingWorx	Allows monitoring of: WAN Type, WAN IP, Mobile Operator Name, Mobile Signal Strength, Mobile Network Type
Cumulocity - Cloud of Things	Allows monitoring of: Device Model, Revision and Serial Number, WAN Type and IP, Mobile Cell ID, ICCID, IMEI, Connection Type, Operator, Signal Strength. Has reboot and firmware upgrade actions
Azure IoT Hub	Can be configured with Data to Server to send all the available parameters to the cloud. Has Direct method support which allows to execute RutOS API calls on the IoT Hub. Also has Plug and Play integration with Device Provisioning Service that allows zero-touch device provisioning to IoT Hubs
AWS IoT Core	Utility to interact with the AWS cloud platform. Jobs Support: Call the device's API using AWS Jobs functionality

System Characteristics

CPU	Mediatek, 580 MHz, MIPS 24KEc
RAM	128 MB
FLASH storage	16 MB

Firmware / Configuration

WEB UI	Update FW from file, check FW on server, configuration profiles, configuration backup
FOTA	Update FW
RMS	Update FW/configuration for multiple devices at once
Keep settings	Update FW without losing current configuration
Factory settings reset	A full factory reset restores all system settings, including the IP address, PIN, and user data to the default manufacturer's configuration

FIRMWARE CUSTOMISATION

Operating system	RutOS (OpenWrt based Linux OS)
Supported languages	Busybox shell, Lua, C, C++
Development tools	SDK package with build environment provided
GPL customization	You can create your own custom, branded firmware and web page application by changing colours, logos, and other elements in our firmware to fit your or your clients' needs
Package Manager	The Package Manager is a service used to install additional software on the device

Location Tracking

GNSS	GPS, GLONASS, BeiDou, Galileo and QZSS
Coordinates	GNSS coordinates via WebUI, SMS, TAVL, RMS
NMEA	NMEA 0183
NTRIP	NTRIP protocol (Networked Transport of RTCM via Internet Protocol)
Server software	Supported server software TAVL, RMS
Geofencing	Configurable multiple geofence zones
Tracking sensitivity	-157 dBm
Position Accuracy	2.5m CEP

Serial

RS232	Terminal block connector: TX, RX, RTS, CTS
RS485	Terminal block connector: D+, D-, R+, R- (2 or 4 wire interface)
Serial functions	Console, Serial over IP, Modem, MODBUS gateway, NTRIP Client

Input / Output

Input	3x Configurable Digital Inputs, 0 - 6 V detected as logic low, 8 - 30 V detected as logic high, 1x Analog input (0 - 30 V)
Output	3x Configurable Digital Outputs, Open collector output, max output 30 V, 300 mA
Events	Email, RMS, SMS
I/O juggler	Allows to set certain I/O conditions to initiate event

Power

Connector	2-pin in 16-pin industrial terminal block
Input voltage range	9 – 30 VDC, reverse polarity protection, surge protection +/-1 kV 50 µs max
Power consumption	Idle: 1.5 W, Max: 3.5 W

Physical Interfaces

Ethernet	1 x RJ45 port, 10/100 Mbps
I/O's	3 x Configurable digital I/O in 16-pin terminal block
Status LEDs	3 x connection status LEDs, 3 x connection strength LEDs, 1 x power LED, 1 x Eth port status LED
SIM	2 x SIM slots (Mini SIM – 2FF), 1.8 V/3 V, double stacked SIM tray
Power	1 x 16-pin terminal block
Antennas	1 x SMA connector for LTE, 1 x SMA connector for GNSS
RS232	4-pin in 16-pin terminal block (TX, RX, RTS, CTS)
RS485	4-pin in 16-pin terminal block (D+, D-, R+, R-)
Reset	Reboot/User default reset/Factory reset button

Physical Specification

Casing material	Aluminium housing
Dimensions (W x H x D)	83 x 25 x 74.2 mm
Weight	165 g
Mounting options	DIN rail, wall mount, flat surface (all require additional kit)

Operating Environment

Operating temperature	-40 °C to 75 °C
Operating humidity	10% to 90% non-condensing
Ingress Protection Rating	IP30

Regulatory & Type Approvals

Regulatory CE, UKCA, EAC, RCM, FCC, IC, CB, WEEE

EMC Emissions & Immunity

Standards EN 55032:2015+A11:2020+A1:2020
 EN 55035:2017+A11:2020
 EN 61000-3-3:2013+A1:2019+A2:2021
 EN IEC 61000-3-2:2019+A1:2021
 EN 301 489-1 V2.2.3
 EN 301 489-19 V2.2.1
 EN 301 489-52 V1.2.1

ESD EN 61000-4-2:2009

Radiated Immunity EN IEC 61000-4-3:2020

EFT EN 61000-4-4:2012

Surge Immunity (AC Mains Power Port) EN 61000-4-5:2014 +A1:2017

CS EN 61000-4-6:2014

DIP EN 61000-4-11:2020

RF

Standards EN 301 511 V12.5.1
 EN 301 908-1 V15.2.1
 EN 301 908-2 V13.1.1
 EN 301 908-13 V13.2.1
 EN 303 413 V1.2.1

Safety

Standards CE: EN IEC 62368-1:2020 + A11:2020, EN IEC 62311:2020
 CB: IEC 62368-1:2018

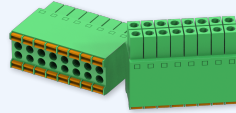
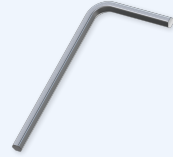
ORDERING**STANDARD PACKAGE*****TRB246****2X8 PIN CONNECTOR****1 X HEX KEY****QSG (QUICK START GUIDE)**

- Gateway TRB246
- [16-pin terminal block](#)
- 1x hex key
- QSG (Quick start guide)
- Packaging box

*Standard package contents may differ based on standard order codes.

For more information on all available packaging options – please [contact us](#) directly.

CLASSIFICATION CODES**HS Code:** 851762**HTS:** 8517.62.00

AVAILABLE VERSIONS

TRB246 0**** EMEA ²	4G (LTE-FDD): B1, B3, B7, B8, B20, B28A 4G (LTE-TDD): B38, B40, B41 3G: B1, B8 2G: B3, B8	TRB246000000 / Standard package
TRB246 1**** South America, Australia, New Zealand, Taiwan	4G (LTE-FDD): B1, B2 ¹ , B3, B4, B5, B7, B8, B28 4G (LTE-TDD): B40 3G: B1, B2, B4, B5, B8 2G: B2, B3, B5, B8	TRB246100300 / Standard package with AU PSU
TRB246 2**** North America	4G (LTE-FDD): B2, B4, B5, B12, B13, B14, B66, B71 3G: B2, B4, B5	TRB246200500 / Standard package with US PSU
TRB246 000A03 Thailand	4G (LTE-FDD): B1, B3, B7, B8, B20 4G (LTE-TDD): B38, B40 3G: B1, B8 2G: B3, B8	TRB246000A03 / Standard package

The price and lead-times for region (operator) specific versions may vary. For more information please [contact us](#).

1 - LTE-FDD B2 does not support Rx-diversity

2 - Regional availability - excluding Russia, Belarus & Iran

TRB246 SPATIAL MEASUREMENTS
PHYSICAL SPECIFICATION

Device housing (W x H x D)*: 83 x 25 x 74.2 mm

Box (W x H x D): 111 x 31 x 89 mm

*Housing measurements are presented without antenna connectors and screws; for measurements of other device elements look to the sections below.

TOP VIEW

The figure below depicts the measurements of device and its components as seen from the top:

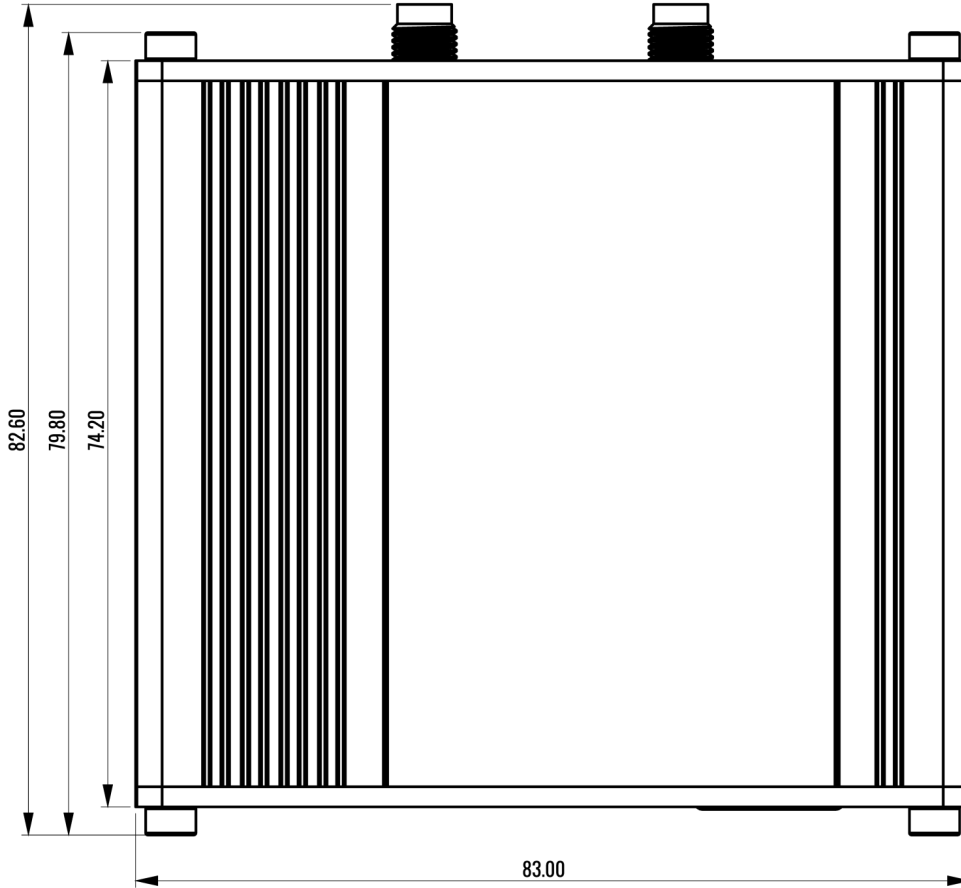

RIGHT VIEW

The figure below depicts the measurements of device and its components as seen from the right side:

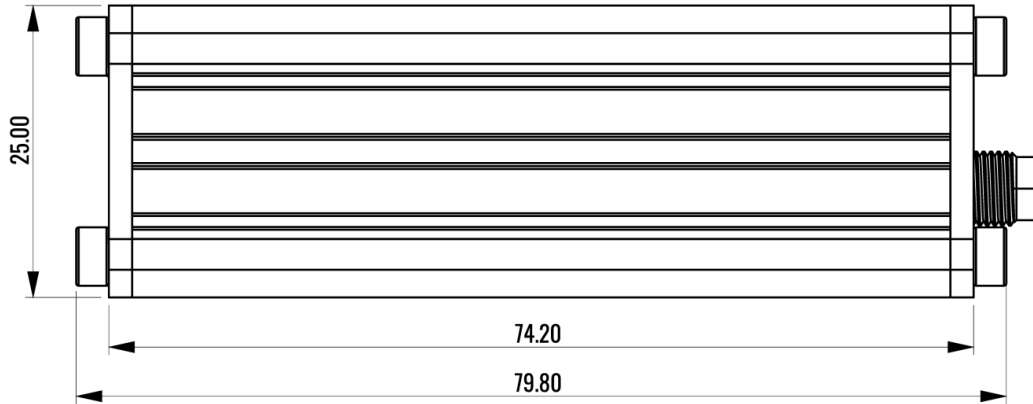

FRONT VIEW

The figure below depicts the measurements of device and its components as seen from the front panel side:

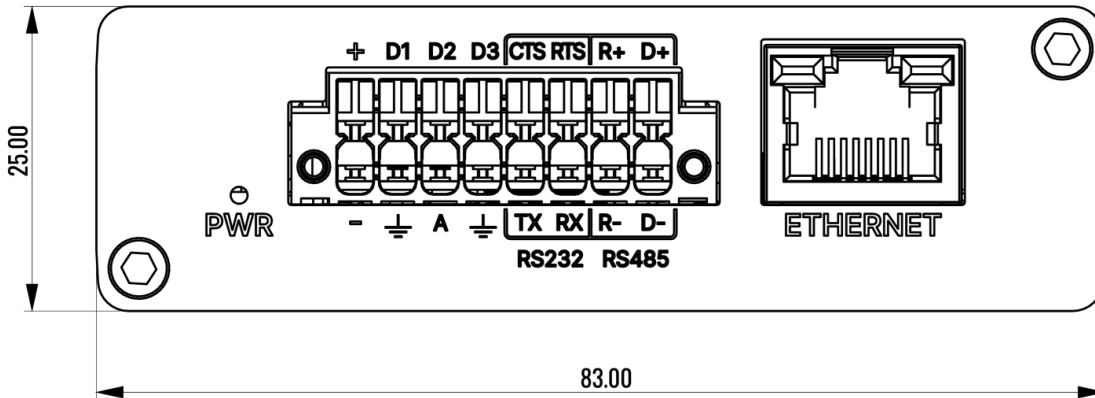

REAR VIEW

The figure below depicts the measurements of device and its components as seen from the back panel side:

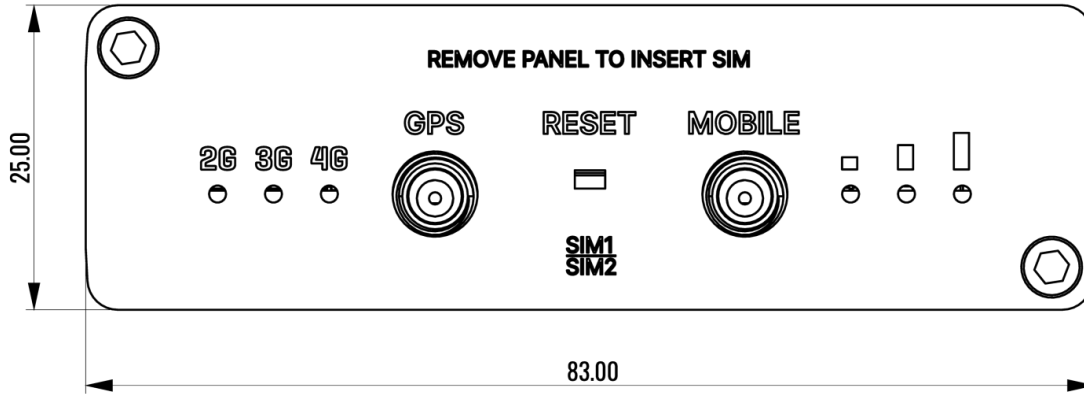

MOUNTING SPACE REQUIREMENTS

The figure below depicts an approximation of the device's dimensions when cables and antennas are attached:

